

Power Monitor Add-on KIT (0486) for LogiCO2 Safety Systems



FUNCTION

The Power Monitor is a surveillance unit which ensures that the personnel are alerted in case there is a power failure that puts the LogiCO2 Safety System out of function. It has a built-in buzzer and place for two AAA alkaline batteries (batteries included).

If there is a power failure the Power Monitor makes an alarm. The Power Monitor will sound the buzzer for at least 12 hours.

If the LogiCO2 Safety System is powered via a UPS power back-up, it is recommended to install a Power Monitor that monitors the UPS-function. In case the UPS's batteries run out, the Power Monitor will give an alarm informing that the LogiCO2 Safety System is out of function.

The three LEDs show the current status:

LED and sound indication	Information
Green LED Continuous LED-light	The Safety System has power
Red LED Continuous beep and LED-light	No power to the Safety System
Red LED Double beep and LED-flash every other second	Power below 18V to the Safety System
Yellow LED Beep and LED-flash every five seconds	Low batteries in the Power Monitor. Replace the batteries.

TECHNICAL DATA

Power supply

- Safety System: 24V DC
- Batteries: 2xAAA Alkaline 1,5V batteries*

Internal battery check: Once per hour

Low power trig point: 18V

No power trig point: Approx 3V

Wiring connections: RJ 45

Acoustic signal-strength: ~80 dBa (1m)

Operating temperature range: 0 to +45°C / +32 to +113°F
Only for indoor use.

Overvoltage: Category II

Pollution degree: II

Approval: Certified by UL

Dimensions (LxWxD): 90 x 161 x 38 mm /
3.5" x 6.3" x 1.5"

Ingress protection: IP54

*NOTE! Do not use Lithium batteries or rechargeable batteries.

YEARLY FUNCTION CONTROL

Please observe!

Since this is a safety product, we recommend that a function control should be conducted at least once a year.

Disconnect the power to the Safety System and check that the Power Monitor activates the "No power" alarm buzzer and red LED. Reconnect the power to the Safety System.

ORDERING EXAMPLE

Item code	Description
0486	Power Monitor for LogiCO2 Safety Systems

Power Monitor Add-on KIT consists of:

Power Monitor for LogiCO2 Safety Systems, incl. cable
RJ45 splitter 1-2

Power Monitor Add-on KIT (0486) for LogiCO2 Safety Systems



INSTALLATION

The Power Monitor can detect a system power failure on both the red and blue cables of the Safety System. Mount the Power Monitor in a suitable location where it is easily seen and heard, preferably next to the Central Unit. Do not cover the Power Monitor.

START-UP

How to start-up Power Monitor in order to avoid activating the buzzer during the start-up:

1. Install the Power Monitor in a suitable location.
2. Remove the cover by unscrewing the five Phillips-screws.
3. Disconnect the power cable **installed in the Power Monitor**.
4. Connect the Power Monitor, preferably directly to the Central Unit, or use a splitter and connect the Power Monitor to the Safety Systems red or blue cabling.
5. Reconnect the power cable in the Power Monitor, and after that, install the two enclosed batteries within 30 seconds. If the batteries are not installed within 30 seconds, the Power Monitor will activate a "low battery" alarm. The alarm will be activated until the next battery check, which is done once every hour. To reset the "low battery" alarm, remove the batteries and go back to step 3.
6. Reassemble the cover and screws in order according to figure 4.

Fig. 1, Power Monitor connected directly to the **Central Unit** of the Safety System

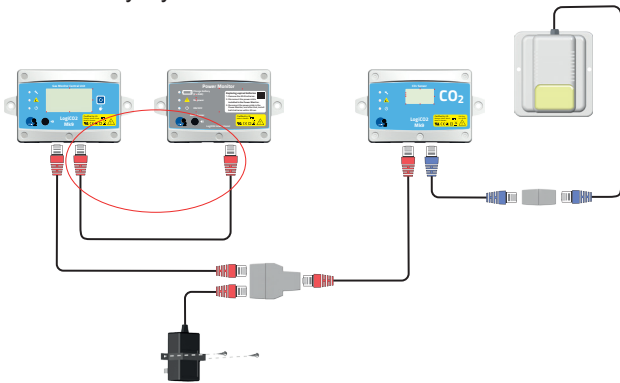

Fig. 2, Power Monitor connected on the **blue cables** of the Safety System

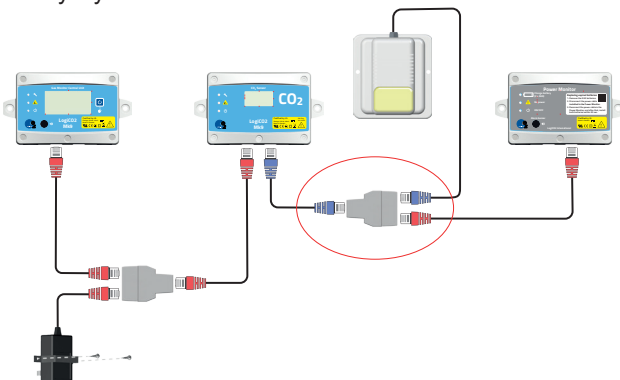
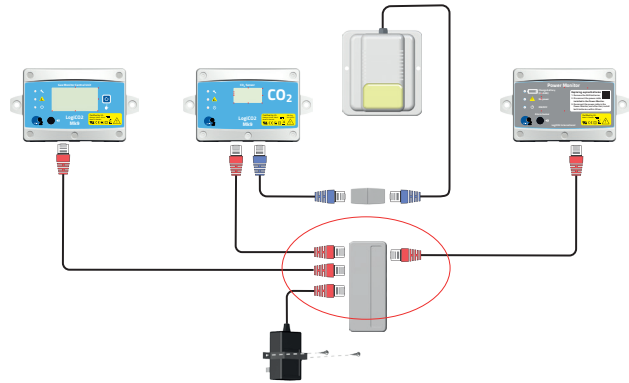

Fig. 3, Power Monitor connected on the **red cables** of the Safety System



REPLACING EXPIRED BATTERIES

Always use two high performance AAA Alkaline batteries (i.e. Duracell Ultra or GP Ultra).

How to replace the batteries in order to avoid activating the buzzer during the exchange:

1. Remove the cover by unscrewing the five Phillips-screws.
2. Remove the AAA batteries.
3. Disconnect the power cable **installed in the Power Monitor**.
4. Reconnect the power cable in the Power Monitor, and after that, install the two new batteries within 30 seconds. If the batteries are not installed within 30 seconds, the Power Monitor will activate a "low battery" alarm. The alarm will be activated until the next battery check, which is done once every hour. To reset the "low battery" alarm, remove the batteries and go back to step 3.
5. Reassemble the cover and screws in order according to figure 4.

Fig. 4, If the cover of the Power Monitor needs to be removed, please observe the following order of screw reassembling.

